



Commercial Microwave Oven

NE-1054

This Commercial Microwave Oven by Panasonic is ideal for full and quick service restaurants, banquets, supermarkets, catering, and institutional applications.

- 1000* Watts of Power
- Capacity: 0.8 Cubic Feet
- “Grab & Go” Door Handle
- Bottom Energy Feed
- Fits One 6" Tall, Half-Size Steam Table Pan with Cover



Pro

Panasonic ideas for life



NE-1054 Commercial Microwave Oven

Additional Features:

- Compact Size
- Stainless Steel Front
- Touch Control Keypad with Braille
- Beep Control (On/Off)
- 10 Programmable Memory Pads; 20 Memory Capability
- 6 Power Levels
- 2- and 3-Stage Cooking
- Programmable and Manual Operations
- Program List/Cycle Counter
- Self Diagnostics
- 99:99 Minute Capacity
- See-Through Oven Door
- Interior Oven Light
- Chef Technical Support
- Anti-Theft Equipped
- Will Ship via UPS
- NSF & UL Commercial Approved

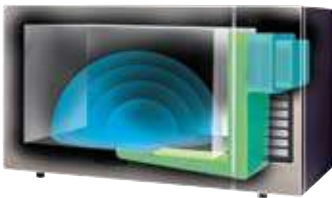

Bottom Energy Feed

The energy travels less distance to reach the food, compared to side or top energy feed, for increased efficiency.

“Grab & Go” Door Handle

Without the hassle of moving parts like those found in push button doors or trigger-activated handles, the “Grab & Go” Door Handle is fast and durable.



Touch-Control Keypad

Featuring an electronic keypad with 10 programmable memory pads and a 20-memory capability, the NE-1054 cooks with speed and precision with its 6 power levels and 2- and 3-stage cooking.

Specifications

| NE-1054 | |
|---------------------------|--|
| Power Source | 120V, 60Hz, Single Phase |
| Receptacle Required | NEMA 5-15 R or NEMA 5-20 R |
| Frequency | 2,450MHz |
| Required Power | 13.4A |
| Output | 1000 Watts* |
| Outer Dimensions (wxdxh) | 20 $\frac{1}{8}$ " x 16 $\frac{9}{16}$ " x 12" |
| Cavity Dimensions (wxdxh) | 13" x 13" x 8 $\frac{1}{16}$ " |
| Net Weight | 34 lbs. |
| Shipping Weight | 39 lbs. |
| Shipping Box Size (wxdxh) | 24 x 18 $\frac{3}{4}$ x 14 $\frac{3}{4}$, 3.8 cu. ft. |
| Timer | 99 Min., 99 Sec. |
| Memory Capability | 20 Programs |

To Specify a Panasonic Commercial Microwave Oven

The NE-1054 Commercial Microwave Oven meets or exceeds all safety performance and sanitation standards set for commercial food service microwave ovens by UL, DHHS, FCC and NSF. Plus, oven shall have output power 1000 Watts*, stainless steel front, bottom energy feed, 10 programmable memory pads, Braille keypad, 20-memory capability, Double Quantity Key, 6 power levels, 2- and 3-stage cooking, programmable lock, unique “quick pick” preset times and self-diagnostics, and Chef/Test Kitchen technical support. 3 years limited warranty. 1 year parts & labor. 3 years magnetron.

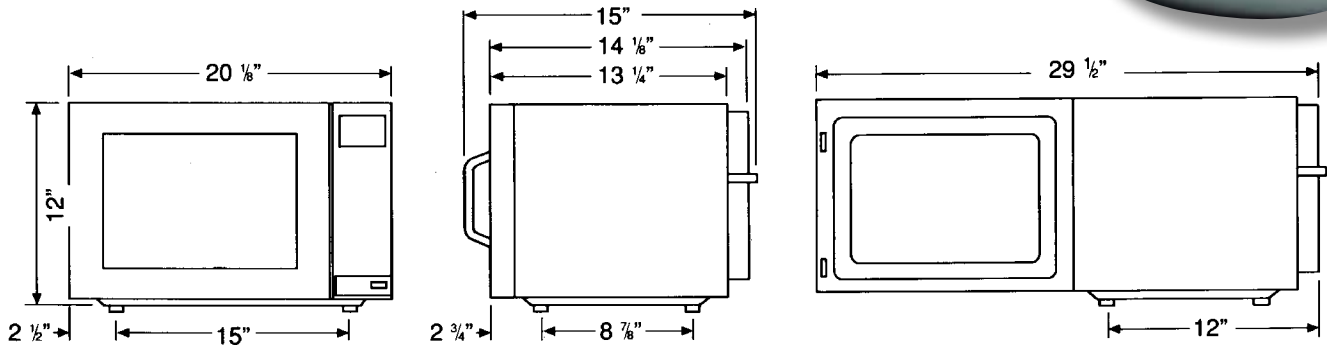

* I.E.C. 60705 Test Procedure. Specifications subject to change without notice.

Panasonic ideas for life

Panasonic Home & Commercial Appliance Group
Panasonic Corporation of North America
Executives Offices: One Panasonic Way, Panazip 1H-2
Secaucus, NJ 07094

Toll-free: **877-CMO-OVEN (266-6836)**
Sales Support, Recipes and Training at: www.panasonic.com/cmo

For a Panasonic Distributor/Services nearest you, 1-800-350-9590