

SLICING

Berkel**829A-PLUS**
GRAVITY FEED SLICER

Model 829A-PLUS

**STANDARD FEATURES**

- 1-speed, ½ HP, totally enclosed and permanently lubricated knife motor.
- Furnished in 115/60/1, 4.0 amps, AC, ETL listed.
- Finish is stainless steel and sanitary anodized aluminum; unit disassembles quickly without tools for easy cleaning.
- 45° product table with removable meat pusher and gauge plate interlock.
- Nominal 14" (350 mm) diameter; hollow ground, hardened and polished forged chromium-plated carbon steel knife.
- Carriage handles food up to 11" (280 mm) wide, by 8½" (216mm) high or 8½" (216 mm) diameter.
- Precise slice adjustment to a thickness of ¼" (19 mm).
- Built-in, non-removable, top-mounted, two stone knife sharpener produces a consistently sharp knife edge.
- Permanent, tapered knife ring guard covers non-slicing portion of knife even when the center plate is removed; ring guard design provides more room behind the knife for easy cleaning.
- Positive, moisture protected, on/off switch with power light indicator.
- Attached 6-foot, flexible, 3-wire cord and plug for grounded receptacle (5-15P).

FEATURES

Berkel Model 829A-PLUS manual gravity feed slicer features Berkel's hollow ground chromium-plated, carbon steel knife and single lever, dual-action, built-in sharpener. The permanent, tapered guard covers the non-slicing portion of the knife, even when the center plate is removed. The 45° table with gauge plate interlock makes product feed easier, creating more consistent and uniform slices with less waste. The ½ HP motor, 14" knife and large product table are ideal for handling oversize meats, cheeses and a variety of other products. The 829A-PLUS is easy to clean and disassembles quickly without tools.

COMPLIES WITH NSF/ANSI STANDARD #8**Berkel**

a division of ITW Food Equipment Group LLC

www.berkequipment.com

P.O. Box 696 ■ Louisville, KY 40201 ■ Toll-free: 1-800-814-2028 ■ Local: 502-778-2791 ■ Quote & Order Fax: 1-800-444-0602

Berkel

829A-PLUS GRAVITY FEED SLICER

SPECIFICATIONS

Motor: 1-speed, ½ HP, totally enclosed, permanently lubricated ball bearings, thermally protected.

Electrical: Furnished in 115/60/1, 4.0 amps, AC, ETL listed.

Finish/Construction: All food contact areas are stainless steel or anodized aluminum including the pusher, gauge plate, product table, center plate, knife ring guard and one-piece base. Slicer disassembles quickly without tools for easy cleaning.

Knife: Nominal 14" (350 mm) diameter, hollow ground, hardened and polished forged chromium-plated carbon steel, rotates at 220 rpm.

Cutting Capacity: Carriage handles food up to 11" (280 mm) wide by 8½" (216 mm) high or 8½" (216 mm) diameter.

Slice Thickness: Precision system provides infinite slice adjustment and consistent cuts of hard or soft foods from tissue thin to ¾" (19 mm).

Full Gravity Feed: Full 45° angle feed with gauge plate interlock requires less mechanical pressure. Equipped with removable anodized aluminum pusher to hold product and minimize waste.

Knife Sharpener: Built-in, non-removable, lever activated, top mounted, two stone system for a lasting, razor-sharp edge.

Knife Ring Guard: Permanent, tapered guard covers non-slicing portion of knife edge even when the center plate is removed. The ring guard is designed to provide added room behind the knife for easy cleaning.

On/Off Switch: Highly reliable, moisture resistant, on/off switch with power light indicator.

Cord and Plug: Attached 6-foot, flexible, 3-wire cord and plug for grounded receptacle (5-15P).

Warranty: All parts, service and travel coverage for one year, excluding wear items.

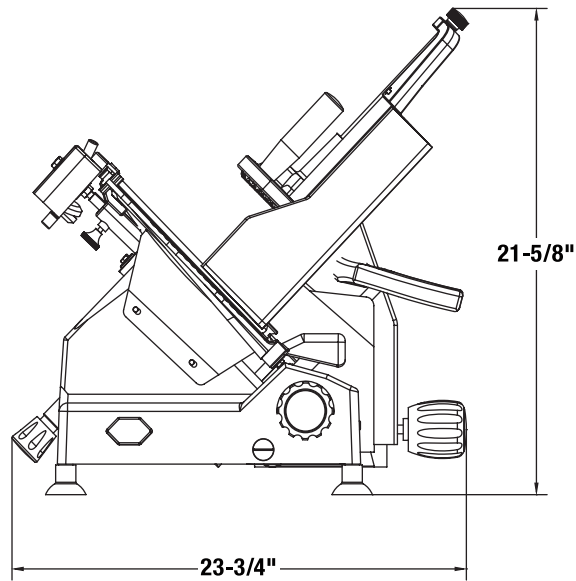
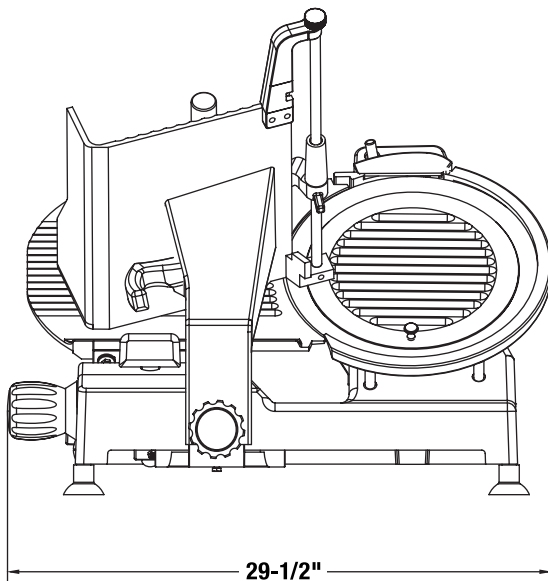

MODEL NUMBER	CUTTING CAPACITY	SLICE THICKNESS	KNIFE DIA.	PRODUCT DIMENSIONS		
				WIDTH	DEPTH	HEIGHT
829A-PLUS	11" (280 mm) wide 8½" (216 mm) high 8½" (216 mm) diameter	to ¾" (19 mm)	14" (350 mm)	23¾" (604 mm)	29½" (750 mm)	21⅝" (550 mm)

MODEL NUMBER	MOTOR	ELECTRICAL	WEIGHT	BOX DIMENSIONS		
				WIDTH	DEPTH	HEIGHT
829A-PLUS	1-speed ½ HP	115/60/1 4.0 amps	Net 91 lbs. (41 kg) Ship 119 lbs. (54 kg)	28½" (724 mm)	33½" (851 mm)	26" (661 mm)

Berkel a division of ITW Food Equipment Group LLC

www.berkelequipment.com

P.O. Box 696 ■ Louisville, KY 40201 ■ Toll-free: 1-800-814-2028 ■ Local: 502-778-2791 ■ Quote & Order Fax: 1-800-444-0602

NOTE: As we continually strive to improve our products, specifications are necessarily subject to change without notice.