

SLICING

Berkel**825A-PLUS**
GRAVITY FEED SLICER

Model 825A-PLUS

**STANDARD FEATURES**

- 1-speed, 1/3 HP, totally enclosed and permanently lubricated knife motor.
- Furnished in 115/60/1, 3.1 amps, AC, ETL listed.
- Finish is stainless steel and sanitary anodized aluminum; unit disassembles quickly without tools for easy cleaning.
- 45° product table with removable meat pusher.
- Nominal 10" (250 mm) diameter; hollow ground, hardened and polished forged chromium-plated carbon steel knife.
- Carriage handles food up to 8 3/4" (222 mm) wide, by 6" (152 mm) high or 7" (178 mm) diameter.
- Precise slice adjustment to a thickness of 9/16" (14 mm).
- Top-mounted, two stone knife sharpener produces a consistently sharp knife edge.
- Permanent, tapered knife ring guard covers non-slicing portion of knife even when the center plate is removed; ring guard design provides more room behind the knife for easy cleaning.
- Positive, moisture protected, on/off switch with power light indicator.
- Attached 6-foot, flexible, 3-wire cord and plug for grounded receptacle (5-15P).

FEATURES

Berkel Model 825A-PLUS manual gravity feed slicer features Berkel's hollow ground chromium-plated, carbon steel knife and built-in sharpener. The permanent, tapered guard covers the non-slicing portion of the knife, even when the center plate is removed. The 45° table makes product feed easier, creating more consistent and uniform slices with less waste. The 1/3 HP motor, 10" knife and large product table are ideal for handling oversize meats, cheeses and a variety of other products. The 825A-PLUS is easy to clean and disassembles quickly without tools. The compact space-saving design is ideal for limited kitchen counter space.

COMPLIES WITH NSF/ANSI STANDARD #8**Berkel**

a division of ITW Food Equipment Group LLC

www.berkequipment.com

P.O. Box 696 ■ Louisville, KY 40201 ■ Toll-free: 1-800-814-2028 ■ Local: 502-778-2791 ■ Quote & Order Fax: 1-800-444-0602

Berkel**825A-PLUS**
GRAVITY FEED SLICER**SPECIFICATIONS**

Motor: 1-speed, 1/3 HP, totally enclosed, permanently lubricated ball bearings, thermally protected.

Electrical: Furnished in 115/60/1, 3.1 amps, AC, ETL listed.

Finish/Construction: All food contact areas are stainless steel or anodized aluminum including the pusher, gauge plate, product table, center plate, knife ring guard and one-piece base. Slicer disassembles quickly without tools for easy cleaning.

Knife: Nominal 10" (250 mm) diameter, hollow ground, hardened and polished forged chromium-plated carbon steel, rotates at 310 rpm.

Cutting Capacity: Carriage handles food up to 8 3/4" (222 mm) wide by 6" (152 mm) high or 7" (178 mm) diameter.

Slice Thickness: Precision system provides infinite slice adjustment and consistent cuts of hard or soft foods from tissue thin to 9/16" (14 mm).

Full Gravity Feed: Full 45° angle feed requires less mechanical pressure. Equipped with removable anodized aluminum pusher to hold product and minimize waste.

Knife Sharpener: Top mounted, two stone system for a lasting, razor-sharp edge.

Knife Ring Guard: Permanent, tapered guard covers non-slicing portion of knife edge even when the center plate is removed. The ring guard is designed to provide added room behind the knife for easy cleaning.

On/Off Switch: Highly reliable, moisture resistant, on/off switch with power light indicator.

Cord and Plug: Attached 6-foot, flexible, 3-wire cord and plug for grounded receptacle (5-15P).

Warranty: All parts, service and travel coverage for one year, excluding wear items.

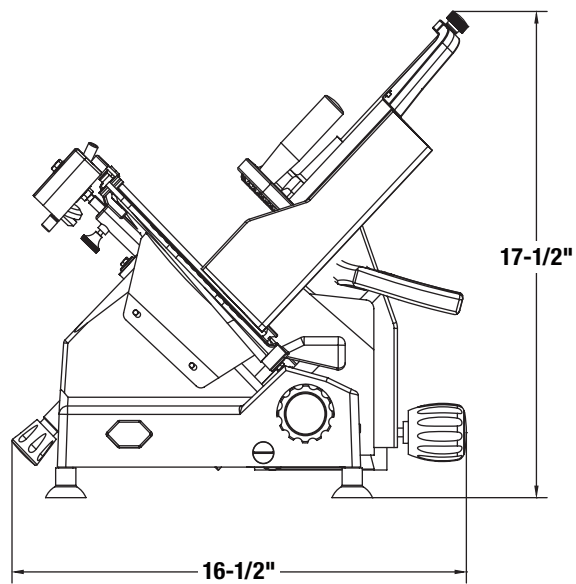
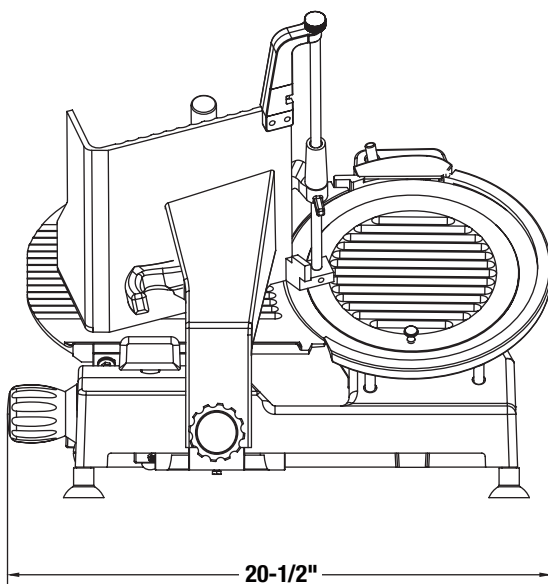

| MODEL NUMBER | CUTTING CAPACITY | SLICE THICKNESS | KNIFE DIA. | PRODUCT DIMENSIONS | | |
|--------------|--|---------------------|-----------------|---------------------|---------------------|---------------------|
| | | | | WIDTH | DEPTH | HEIGHT |
| 825A-PLUS | 8 3/4" (222 mm) wide 6" (152 mm) high 7" (178 mm) diameter | to 9/16" (14 mm) | 10" (250 mm) | 16 1/2" (419 mm) | 20 1/2" (521 mm) | 17 1/2" (445 mm) |

| MODEL NUMBER | MOTOR | ELECTRICAL | WEIGHT | BOX DIMENSIONS | | |
|--------------|-------------------|----------------------|---|---------------------|---------------------|---------------------|
| | | | | WIDTH | DEPTH | HEIGHT |
| 825A-PLUS | 1-speed 1/3 HP | 115/60/1 3.1 amps | Net 37 lbs. (17 kg) Ship 47 lbs. (21 kg) | 22 1/2" (572 mm) | 23 1/2" (597 mm) | 23 1/2" (597 mm) |

Berkel a division of ITW Food Equipment Group LLC

www.berkequipment.com

P.O. Box 696 ■ Louisville, KY 40201 ■ Toll-free: 1-800-814-2028 ■ Local: 502-778-2791 ■ Quote & Order Fax: 1-800-444-0602

NOTE: As we continually strive to improve our products, specifications are necessarily subject to change without notice.