



# TOAST-QWIK® ELECTRIC CONVEYOR TOASTERS

Models TQ-10, -400, -400BA, -400H, -800, -800BA, -800H, -800HBA, -1200, -1800, -1800BA, -1800H, -1800HBA

The Hatco Toast-Qwik® is an economical conveyor toaster with fast, dependable and versatile toasting, offering 300 to 1800 slices per hour. Hatco toasters utilize conveyor speed, not temperature to determine toasting color. This method allows for *instant* adjustment of toasting time to match the bread product being toasted.

## FLEXIBILITY

For uniformly colored golden-brown toast, as well as bagels, buns, and English muffins, Toast-Qwik Conveyor Toasters provide the optimum in features, quality and value. The electronic controls precisely regulate both top and bottom heating elements for perfect toasting every time. The exclusive, patented ColorGuard sensing system monitors cabinet temperature and adjusts conveyor speed during high usage periods to assure uniform toast. The power save mode with indicator light saves energy and money during slow periods.

Hatco versatility offers standard and bagel models, as well as versions with a taller opening for thicker products and a high-speed model. The efficient design of front or rear discharge allows Toast-Qwik to be placed where it is most convenient – for sending product to operator side or customer/server.

Hatco Toast-Qwik toasters feature permanently lubricated ball bearing motor and heating elements guaranteed against burnout and breakage for two years.

## QUALITY

The following features assure the finest performance for years to come:

- ColorGuard sensing system assures toast uniformity (excluding TQ-10).
- Electronic infinite controls regulate top and bottom heat (excluding TQ-10).
- Easy-to-load rack with front or rear discharge.
- Power save mode conserves energy and saves money (excluding TQ-10).
- Opening height for H and HBA models is 3" (76 mm) for all other models the opening height is 2" (51 mm).
- Aluminum toast collector tray prevents condensation (excluding TQ-10).
- Insulation and an interior fan provide cool surface temperatures.



Model TQ-400



Model TQ-800HBA



Model TQ-800H



Model TQ-1800H

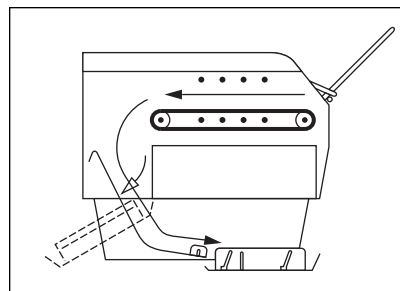

Product Flow



Model TQ-10

For lower volume applications, the Toast-Qwik TQ-10 model is an economical conveyor toaster with the capacity of up to 300 slices per hour. Features include independent controls for upper and lower elements allowing single- or double-side toasting, conveyor speed to determine the toast color, and an easy-to-load rack with front or rear discharge. Durable painted steel top and aluminized steel construction assures years of trouble-free service.



HATCO CORPORATION P.O. Box 340500 Milwaukee, WI 53234-0500 U.S.A.  
 (800) 558-0607 • (414) 671-6350 • Fax (800) 543-7521 • Int'l Fax (414) 671-3976  
[www.hatcocorp.com](http://www.hatcocorp.com) • E-mail: [equipsales@hatcocorp.com](mailto:equipsales@hatcocorp.com)

ONE YEAR ON-SITE PARTS AND LABOR WARRANTY, PLUS ONE ADDITIONAL YEAR PARTS-ONLY WARRANTY ON ALL METAL SHEATHED HEATING ELEMENTS



# TOAST-QWIK® ELECTRIC CONVEYOR TOASTERS

Models TQ-10, -400, -400BA, -400H, -800, -800BA, -800H, -800HBA, -1200, -1800, -1800BA, -1800H, -1800HBA

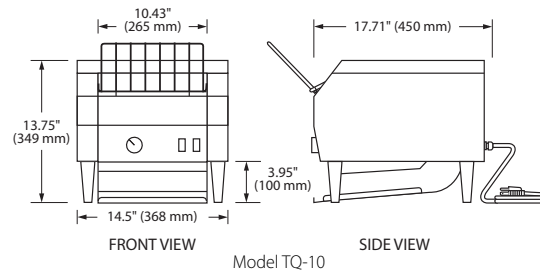
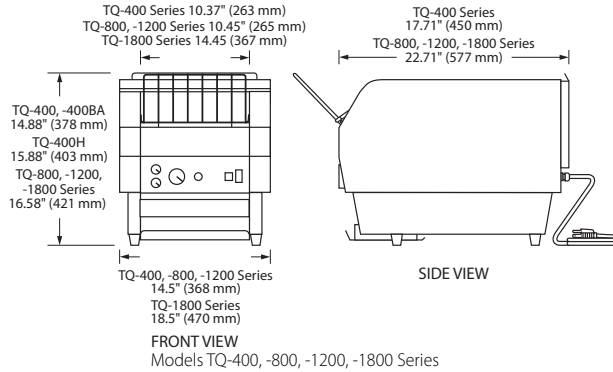

## SPECIFICATIONS

Model	kW	Type	Cap./Min. <sup>†</sup>	Shipping Weight
TQ-10	1.8	All	5 slices	42 lbs. (19 kg)
TQ-400	1.8*	All	6 slices	48 lbs. (22 kg)
TQ-400BA <sup>▼</sup>	1.8	Bagels or Buns	6 slices	48 lbs. (22 kg)
TQ-400H	2.2	All	6 slices	48 lbs. (22 kg)
TQ-800	3.3	All	14 slices	62 lbs. (28 kg)
TQ-800BA <sup>▼</sup>	3.3	Bagels or Buns	14 slices	62 lbs. (28 kg)
TQ-800H	3.3	All	13 slices	62 lbs. (28 kg)
TQ-800HBA <sup>▼</sup>	3.3	Bagels or Buns	14 slices	62 lbs. (28 kg)
TQ-1200	4.0	All	20 slices	65 lbs. (29 kg)
TQ-1800	4.4	All	30 slices	75 lbs. (34 kg)
TQ-1800BA <sup>▼</sup>	4.6	Bagels or Buns	30 slices	75 lbs. (34 kg)
TQ-1800H	4.6	All	20 slices	75 lbs. (34 kg)
TQ-1800HBA <sup>▼</sup>	4.6	Bagels or Buns	30 slices	75 lbs. (34 kg)

<sup>†</sup> Toasting capacity may vary by product. Toasting of coated products is not recommended.

\* 120 volts only. 2.2 kW for 208 and 240 volt models.

<sup>▼</sup> BA models toast one side only.

Toast-Qwik can be shipped United Parcel Service or FedEx Small Package.

## Selector Chart

(Based on serving 2 slices per customer.)

Number of Customers	Serving Time			
	TQ-10, -400, -400BA, -400H	TQ-800, -800BA, -800H, -800HBA	TQ-1200, -1800H	TQ-1800, -1800BA, -1800HBA
30	12 Minutes	5 Minutes	3 Minutes	2 Minutes
60	24 Minutes	9 Minutes	6 Minutes	4 Minutes
90	36 Minutes	13 Minutes	9 Minutes	6 Minutes
120	48 Minutes	18 Minutes	12 Minutes	8 Minutes

## DIMENSIONS

TQ-10: 14.5"W x 17.71"D x 13.75"H (368 x 450 x 349 mm).

TQ-400, -400BA: 14.5"W x 17.71"D x 14.88"H (368 x 450 x 378 mm).

TQ-400H: 14.5"W x 17.71"D x 15.88"H (368 x 450 x 403 mm).

Tray extends 2.5" (64 mm) in rear.

TQ-800 Series, -1200: 14.5"W x 22.71"D x 16.58"H (368 x 577 x 421 mm).

Tray extends 6.5" (165 mm) in rear.

TQ-1800 Series: 18.5"W x 22.71"D x 16.58"H (470 x 577 x 421 mm).

Tray extends 6.5" (165 mm) in rear.

## VOLTAGE

TQ-10, -400 Series: 120, 208, and 240 volts, 60 Hz, single phase.

TQ-800, -1200, -1800 Series: 208 and 240 volts, 60 Hz, single phase.

## CORD LOCATION

Bottom right corner on back of unit.

## PLUG CONFIGURATIONS

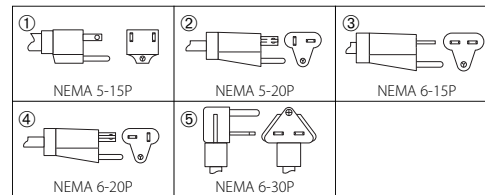

## AMP RATING & PLUG SUPPLIED

Model	120V	208V	240V
TQ-10	15.0 amps ①	8.8 amps ③	7.6 amps ③
TQ-400	15.0 amps ①	10.7 amps ③	9.3 amps ③
TQ-400BA	14.8 amps ①	9.0 amps ③	7.8 amps ③
TQ-400H	—	10.7 amps ③	9.3 amps ③
TQ-800, -800H	—	16.0 amps ④	13.9 amps ③
TQ-800BA, -800HBA	—	15.8 amps ④	13.7 amps ③
TQ-1200	—	19.4 amps ⑤	16.8 amps ⑤
TQ-1800	—	21.4 amps ⑤	18.5 amps ⑤
TQ-1800H	—	22.4 amps ⑤	19.4 amps ⑤
TQ-1800BA, -1800HBA	—	22.0 amps ⑤	19.1 amps ⑤

\*For Canada.

## OPTIONS (NOT FOR RETROFIT)

Automatic Power Save Mode (TQ-400, -800, -1200, -1800 Series only)

## ACCESSORIES

20 Amp Receptacle, 125V (NEMA 5-20R)

20 Amp Receptacle, 250V (NEMA 6-20R)

30 Amp Receptacle, 250V (NEMA 6-30R)

Security Package

Additional Extended Feed Guide (not available on TQ-1800 series)

## PRODUCT SPECS

### Conveyor Toaster

The electric Conveyor Toaster shall be a Hatco Model ... as manufactured by the Hatco Corporation, Milwaukee, WI 53234 U.S.A.

The toaster shall have the capacity to toast up to ... pieces per minute and it shall be rated at ... kW, ... volts, single phase.

The toaster shall be of stainless steel (or aluminized TQ-10) design and shall include a front mounted control panel with state-of-the-art electronic top and bottom heat controls, ColorGuard sensing system (patented), variable speed control, power save mode with indicator light

and a toast collector pan (except TQ-10).

The toaster will have metal sheathed heating elements and factory attached UL listed cord and plug.

TQ-10 will have a durable painted steel top and aluminized steel construction with controls for power, heating elements, and conveyor speed.

One year on-site parts and labor warranty, plus one additional year parts-only warranty on all metal sheathed heating elements, with 24/7 service (U.S. and Canada only).

HATCO CORPORATION P.O. Box 340500 Milwaukee, WI 53234-0500 U.S.A. • (800) 558-0607 • (414) 671-6350  
Fax (800) 543-7521 • Int'l. Fax (414) 671-3976 • www.hatcocorp.com • E-mail: equipsales@hatcocorp.com