

Project Name: \_\_\_\_\_ AIA#: \_\_\_\_\_

Model #: \_\_\_\_\_ Location: \_\_\_\_\_

SIS#: \_\_\_\_\_ Item #: \_\_\_\_\_ Quantity: \_\_\_\_\_



# 30 Quart Floor Mixers

## Model

- SPC30 - 30 Quart Planetary Mixer
- SPC30P - 30 Quart Planetary Pizza Mixer

### Complies to the following Canadian requirements:

- NF 454-00
- CSA Z432-04
- CSA, C22.2



GLOBE FOOD EQUIPMENT COMPANY

30 Quart Floor Mixers

SPC30/SPC30P

## Standard Features

- Powerful custom built motor - 1 HP (SPC30) or 1 ½ HP (SPC30P)
- Three fixed speeds
- Gear-driven, high torque transmission
- Heat-treated hardened steel alloy gears and shafts
- Permanently lubricated transmission
- Thermal overload protection
- Front-mounted digital controls with 60 minute timer and last batch recall
- Rigid cast iron body
- NSF approved enamel gray paint
- Industry standard #12 attachment hub
- Safety interlocked bowl guard and bowl lift
- Non-slip rubber feet
- 6 foot cord and ground plug
- High-quality stainless steel removable bowl guard with built-in ingredient chute
- Interlocking guard is easy to attach and remove for cleaning
- Dish machine safe



Bowl Guard

## Standard Accessories:

- 30 quart stainless steel bowl
- Flat beater (aluminum)
- Stainless steel wire whip
- Spiral dough hook (aluminum)

## Optional:

- Slicer/shredder/grater for #12 hub
- Meat grinder for #12 hub
- Flat beater (stainless steel)
- 20 Qt adapter kit

(More options on back)

## Warranty

- Two-year parts and one-year labor

Approved by: \_\_\_\_\_ Date: \_\_\_\_\_



# 30 Quart Floor Mixers

# SPC30/SPC30P

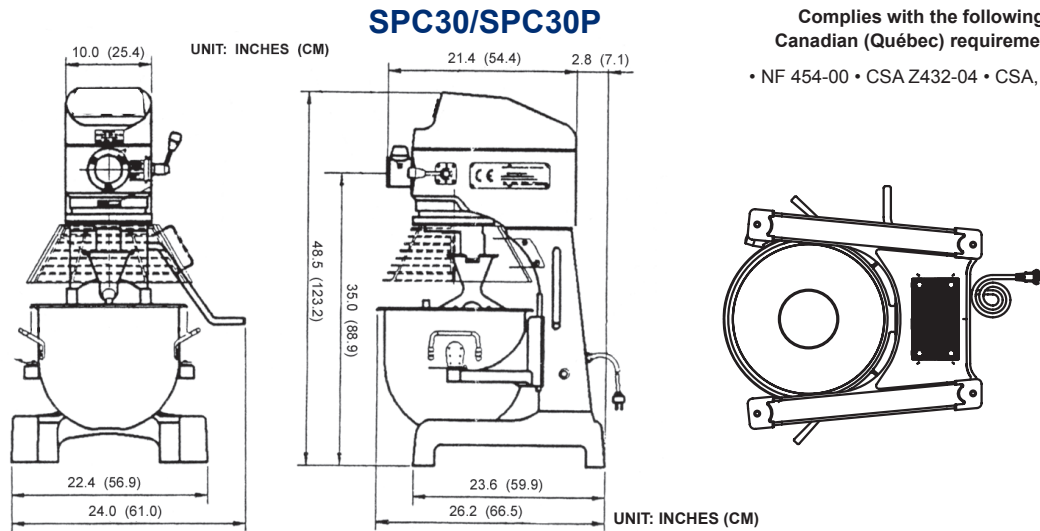

Complies with the following Canadian (Québec) requirements  
 • NF 454-00 • CSA Z432-04 • CSA, C22.2

Drawings available through KCL. [www.kclcad.com](http://www.kclcad.com)

Model	Elevation	Right	Plan	Back	BIM 3D	Revit
SPC30						
SPC30P						

## SPECIFICATIONS

Model	Motor	Volts	Amps	Transmission Type	Capacity	Controls	Agitator Speeds (RPMs)			Attachment Speeds (RPMs)		
							1st	2nd	3rd	1st	2nd	3rd
SPC30/	1 HP	115/60/1	16	Gear	31.7 qt / 30 L	Front-mounted digital controls & timer	92	164	317	62	111	215
SPC30P	1-1/2 HP	220/60/1	12									

**Cord & Plug:** Attached 6 foot flexible 3-wire cord with molded plug fits a grounded receptacle. SPC30 NEMA 5-20P (1) & SPC30P NEMA 6-20P (1)

### STANDARD ACCESSORIES:

- 30 Quart #304 series stainless steel bowl
- Aluminum spiral dough hook and flat beater
- Stainless steel wire whip and bowl guard with built-in ingredient chute

### OPTIONAL ATTACHMENTS & ACCESSORIES:

- **XXBOWL-30** Stainless steel bowl
- **XXBEAT-30** Alum. flat beater
- **XXBEAT-30SS** S/S flat beater
- **XXHOOK-30** Alum. dough hook
- **XXWHIP-30** S/S wire whip
- **XXHDWHIP30-4** Heavy-duty 4 mm S/S wire whip
- **XXSCRIP-30** scraper with mounting kit

### • XXACC20-30 Adapter kit - 20 qt bowl, hook, beater and whip

### Chopper Plate Sizes Available:

- **CP02-12** 1/16" (2 mm)
- **CP04-12** 5/32" (4 mm)
- **CP05-12** 3/16" (5 mm)
- **CP06-12** 1/4" (6 mm)
- **CP08-12** 5/16" (8 mm)
- **CP10-12** 3/8" (10 mm)
- **CP12-12** 1/2" (12 mm)
- **CP14-12** 9/16" (14 mm)
- **CP16-12** 5/8" (16 mm)
- **CP18-12** 11/16" (18 mm)
- **CP00-12** Stuffing Plate
- **XST12** 1/2" stuffing tube (sheep)
- **XST34** 3/4" stuffing tube (hog)
- **XMCA-SS** Meat Grinder Assembly (Polished stainless steel cylinder, worm gear, ring, and s/s pan. Includes knife, 3/16" plate, and pusher.)

- **XXCK** Chopper knife for the XMCA-SS
- **XASP** Adjustable slicing plate (for vegetables only)
- **XVSGH** 9" Slicer/Shredder/Grater Housing Only (no plates included-must select from plates listed below)
- **XPH** Plate holder -\*only 1 required

### Shredding Plates:

- **XSP332\*** 3/32" (2.3 mm)
- **XSP316\*** 3/16" (4.7 mm)
- **XSP14\*** 1/4" (6.3 mm)
- **XSP516\*** 5/16" (7.9 mm)
- **XSP12\*** 1/2" (12.7 mm)
- **XGP\*** Grating plate

### FACTORY INSTALLED OPTION:

- **XXCORR-30** Correctional package includes tamper resistant external fasteners.
- **XXCORR-30P** Correctional package includes tamper resistant external fasteners.

## DIMENSIONS & SHIPPING INFORMATION

Freight Class **85**

Cartons are reinforced for shipping. The weight and dimensions of this reinforced carton are included below and may vary from shipment to shipment. **This product ships on a pallet.**

Model	Foot Print	Overall Dimensions	Net Weight	Shipping Dimensions	Shipping Weight
SPC30/	23.6" D x 22.4" W	26.2" L x 22.4" W x 48.5" H	396 lbs.	48" L x 46" W x 64" H	565 lbs.
SPC30P	(60 cm x 57 cm)	(66.5 cm x 57 cm x 123 cm)	(180 kg)	(122 cm x 122 cm x 163 cm)	(256 kg)