

Project Name: \_\_\_\_\_ AIA#: \_\_\_\_\_

Model #: \_\_\_\_\_ Location: \_\_\_\_\_

SIS#: \_\_\_\_\_ Item #: \_\_\_\_\_ Quantity: \_\_\_\_\_



# 20 Quart Bench Mixer

## Model

SPC20 - 20 Quart Planetary Mixer

Complies to the following Canadian requirements:

- NF 454-00
- CSA Z432-04
- CSA, C22.2



## Standard Features

- Powerful 1/2 HP custom built motor
- Three fixed speeds
- Gear-driven, high torque transmission
- Heat-treated hardened steel alloy gears and shafts
- Permanently lubricated transmission
- Thermal overload protection
- Front-mounted digital controls with 60 minute timer and last batch recall
- Rigid cast iron body
- NSF approved enamel gray paint
- Industry standard #12 attachment hub
- Safety interlocked bowl guard and bowl lift
- Non-slip rubber feet
- 6 foot cord and ground plug
- High-quality stainless steel removable bowl guard with built-in ingredient chute
- Interlocking guard is easy to attach and remove for cleaning
- Dish machine safe

Bowl Guard



## Standard Accessories:

- 20 quart stainless steel bowl
- Flat beater (aluminum)
- Stainless steel wire whip
- Spiral dough hook (aluminum)

## Warranty

- Two-year parts and one-year labor

## Optional:

- Slicer/shredder/grater for #12 hub
- Meat grinder for #12 hub
- Flat beater (stainless steel)
- Spiral dough hook (stainless steel)
- 10 Qt adapter kit
- 12 Qt adapter kit
- Mixer table with undershelf

(More options on back)

Approved by: \_\_\_\_\_ Date: \_\_\_\_\_



# 20 Quart Bench Mixer

# SPC20

## SPC20

Complies with the following Canadian (Québec) requirements

- NF 454-00 • CSA Z432-04 • CSA, C22.2

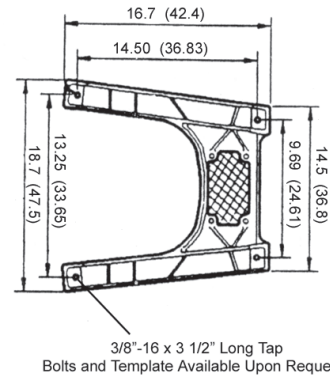
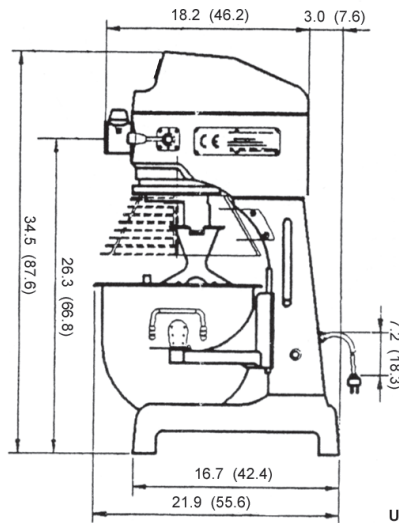
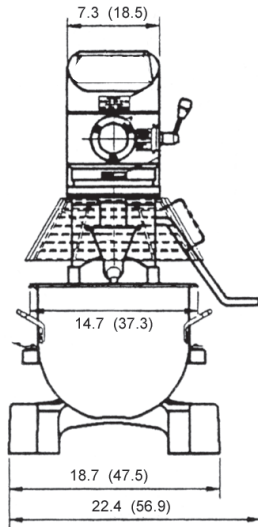

3/8"-16 x 3 1/2" Long Tap Bolts and Template Available Upon Request

UNIT: INCHES (CM)

Drawings available through KCL. [www.kclcad.com](http://www.kclcad.com)

Model	Elevation	Right	Plan	Back	BIM 3D	Revit
SPC20						

## SPECIFICATIONS

Model	Motor	Volts	Amps	Transmission Type	Capacity	Controls	Agitator Speeds (RPMs)			Attachment Speeds (RPMs)		
							1st	2nd	3rd	1st	2nd	3rd
SPC20	1/2 HP	115/60/1	6	Gear	20 qt / 19 L	Front-mounted digital controls & timer	104	194	353	59	110	201

**Cord & Plug:** Attached 6 foot flexible 3-wire cord with molded plug fits a grounded receptacle. NEMA 5-15P (⚠)

### STANDARD ACCESSORIES:

- 20 Quart #304 series stainless steel bowl
- Aluminum spiral dough hook and flat beater
- Stainless steel wire whip and bowl guard with built-in ingredient chute

### OPTIONAL ATTACHMENTS & ACCESSORIES:

- **XXBOWL-20** Stainless steel bowl
- **XXBEAT-20** Alum. flat beater
- **XXBEAT-20SS** S/S flat beater
- **XXHOOK-20** Alum. dough hook
- **XXHOOK-20SS** S/S dough hook
- **XXJHOOK-20** Alum. J dough hook
- **XXWHIP-20** S/S wire whip
- **XXHDWHIP20-4** Heavy-duty 4 mm S/S wire whip

### • XXAWHIP-20 S/S Aileron (wing) whip

- **XXSCR-20** scraper with mounting kit
- **XXACC10-20** Adapter kit - 10 qt bowl, hook, beater and whip
- **XXACC12-20** Adapter kit - 12 qt bowl, hook, beater and whip
- **XXPASTRY-20** Alum. pastry knife
- **XTable** S/S countertop mixer table with under shelf (30" W x 24" D x 24" H)

### • Chopper Plate Sizes Available:

- CP02-12** 1/16" (2 mm)
- CP04-12** 5/32" (4 mm)
- CP05-12** 3/16" (5 mm)
- CP06-12** 1/4" (6 mm)
- CP08-12** 5/16" (8 mm)
- CP10-12** 3/8" (10 mm)
- CP12-12** 1/2" (12 mm)
- CP14-12** 9/16" (14 mm)

### CP16-12 5/8" (16 mm)

### CP18-12 11/16" (18 mm)

### CP00-12 Stuffing Plate

### • XST12 1/2" stuffing tube (sheep)

### • XST34 3/4" stuffing tube (hog)

### • XMCA-SS Meat Grinder

Assembly (Polished stainless steel cylinder, worm gear, ring, and s/s pan. Includes knife, 3/16" plate, and pusher.)

### • XXCK Chopper knife for the XMCA-SS

### • XASP Adjustable slicing plate (for vegetables only)

### • XVSGH 9" Slicer/Shredder/Grater Housing Only (no plates included-must select from plates listed below)

### • XPH Plate holder -\*only 1 required

### Shredding Plates:

- XSP332\*** 3/32" (2.3 mm)
- XSP316\*** 3/16" (4.7 mm)
- XSP14\*** 1/4" (6.3 mm)
- XSP516\*** 5/16" (7.9 mm)
- XSP12\*** 1/2" (12.7 mm)
- XGP\*** Grating plate

### FACTORY INSTALLED OPTION:

- **XXCORR-20** Correctional package includes tamper resistant external fasteners.

## DIMENSIONS & SHIPPING INFORMATION

Freight Class **85**

Cartons are reinforced for shipping. The weight and dimensions of this reinforced carton are included below and may vary from shipment to shipment. **This product ships on a pallet.**

Model	Foot Print	Overall Dimensions	Net Weight	Shipping Dimensions	Shipping Weight
SPC20	16.7" D x 18.7" W (42 cm x 46 cm)	22" L x 22.4" W x 34.5" H (56 cm x 57 cm x 87.6 cm)	199 lbs. (80 kg)	40" L x 32" W x 48" H (102 cm x 81 cm x 122 cm)	270 lbs. (122 kg)