

Project \_\_\_\_\_

Item # \_\_\_\_\_

Quantity \_\_\_\_\_



RC1



## Rice Cooker / Warmer

*Chefmate® Countertop Equipment*

### Model

RC1 Countertop Rice Cooker / Warmer



GLOBE FOOD EQUIPMENT COMPANY

Rice Cooker / Warmer

RC1

### Standard Features

- Single switch for cook-to-warm
- Stainless steel body and lid
- Cooks up to 25 one-cup servings
- Built-in thermostat
- Removable pot with non-stick surface
- Over-heat protection with manual reset
- 1600 watts for cooking rice
- Measuring cup and scoop included
- Attached 4½-foot power cord and NEMA 5-15plug

### Warranty

- One-year parts and labor

Approved By: \_\_\_\_\_

Date: \_\_\_\_\_



**GLOBE FOOD EQUIPMENT COMPANY**

[www.globeslicers.com](http://www.globeslicers.com)

2153 Dryden Rd.  
Dayton, OH 45439  
Phone: 937-299-5493  
Phone: 800-347-5423  
Fax: 937-299-4147



# Rice Cooker / Warmer

# RC1

### For Indoor Use Only

#### Electrical:

RC1 - 120V, 1600W, 4½-foot flexible, three-wire cord with attached ground plug. NEMA 5-15P

**Construction:** Stainless steel body and lid.

**Standard Equipment:** Standard equipment includes non-stick inner cooking pot, stainless steel lid, measuring cup and serving scoop.

## Specifications

**Temperature Controls:** This function controls cookware to a precise temperature for cooking.  
**Do not operate cooker while empty.**

**Cook and Hold:** Rice Cooker cooks rice and then holds rice at serving temperature.

**Over-heat Reset Push Button:** Supplied with a over-heat manual reset push button for temperature overload and safety.

#### Additional Optional Accessories

- Lid
- Inner pot

#### Dimensions RC1:

Foot Print = 16.5" Diameter (42 cm)  
Overall Length = 16.5" (44.5 cm)  
Overall Width = 16.5" (42 cm)  
Overall Height = 11.3" (29 cm)

#### Shipping Information:

Net Weight: 11 lbs (5 kg)  
Shipping Weight: 12.2 lbs (5.5 kg)

#### Shipping Dimensions:

17" W x 17" D x 12" H  
(43.2 cm x 43.2 cm x 30.5 cm)

Cartons are reinforced for shipping. The weight and dimensions of this reinforced carton are included above and may vary from shipment to shipment.

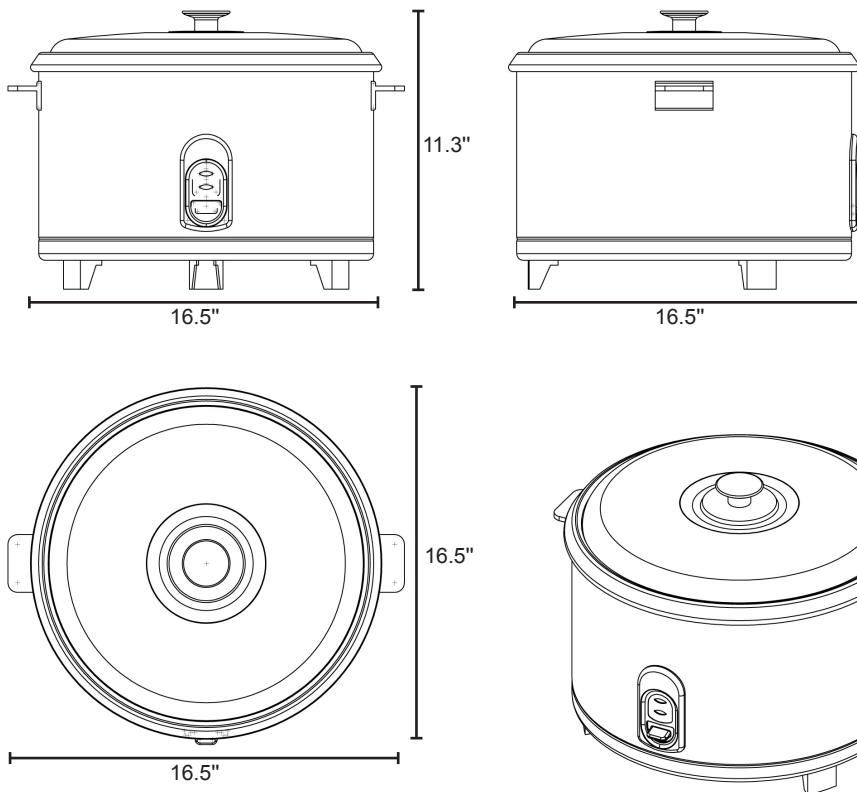

Plug Type - NEMA 5-15



## GLOBE FOOD EQUIPMENT COMPANY

[www.globeslicers.com](http://www.globeslicers.com)

2153 Dryden Rd.  
Dayton, OH 45439  
Phone: 937-299-5493  
Phone: 800-347-5423  
Fax: 937-299-4147

Printed in U.S.A. 3-2011

Specifications are subject to change without notice.