



Project name:	
Location:	
Item:	Qty:
Model:	

# F-180P

HIGH-TEMP UNDERCOUNTER  
DISHWASHER



## CONSTRUCTION FEATURES

- Body, external housing, wash tank, and all chassis components in brushed stainless steel 304 18/10
- Noise 58 dBA due to utilization of double-wall insulated panels
- Deep drawn inner wash chamber provide for maximum sanitation
- Upper and lower wash and rinse revolving arms constructed of stainless steel; easy to remove and clean without the need for tools
- Intergrated AISI 18/10 stainless steel booster with insulated lining
- Safety micro-switch on the door to interrupt wash pump action
- Independently-operated heating elements alternating between booster and wash tank
- Alternating heating elements reducing maximum absorption thereby reducing energy costs
- Built for free standing installation with side and top panels of double-walled construction for low heat and noise emissions
- Standard insulated top and side panels
- Automatic fill and water level reguation of the wash tank
- Wash pump protected with filter plus additional shield for tank element
- Deep drawn inner wash chamber provide for maximum sanitation
- Entire wash tank area protected with perforated stainless steel scrap filters to facilitate maintenance
- Door-opening with overall clearance of 12.5" (32 cm)
- Slide out intergrated front control panel provides easy access for service
- Individual digital gauges for both wash and rinse temperatures
- Thermostatic control of wash and rinse temperatures ensure optimum results
- Standard equipment includes: One open combination rack and one peg dish rack 19.75" x 19.75" (500 mm x 500 mm)

## TECHNICAL FEATURES

- **Rack capacity:** 19.75" x 19.75" (500 mm x 500 mm)
- **Complete operating cycle:** 145 seconds wash and 15 seconds rinse
- **Wash tank capacity:** 6.34 U.S. gallons (24 litres)
- **Wash tank element:** 2800 watts
- **Wash temperature:** 150°F (65°C)
- **Booster capacity:** 1.85 U.S. gallons (7.0 litres)
- **Booster element:** 4000 watts
- **Booster (water) temperature:** 185°F - 194°F (85°C - 90°C)
- **Power supply :** 208-240/60/1
- **Amperage:** 23.5 amps
- **Motor-pump:** 1.0 H.P. with thermal overload protection
- **Maximum power rating:** 4850 watts
- **Water consumption:** 0.74 U.S. gallons per cycle (2.8 litres)
- **Water consumption per hour:** 24.1 U.S. gallons (91.2 litres max.)
- **Water supply:** 1/2" hot water supply 140°F / 60°C
- **Recommended pressure:** 30 p.s.i. (dynamic) (PRV may be required)
- **Water inlet connection:** 3/4" male hose connector (hose included)
- **Drain connection:** 1" ID (25.4mm) max height 36" (915mm) (hose included)
- **Shipping weight:** 165 lbs (75 kg)

## OPTIONAL ACCESSORIES

- Pressure reducing valve (PRV) kit
- Stainless steel stand (12" high)
- Drain water tempering kit

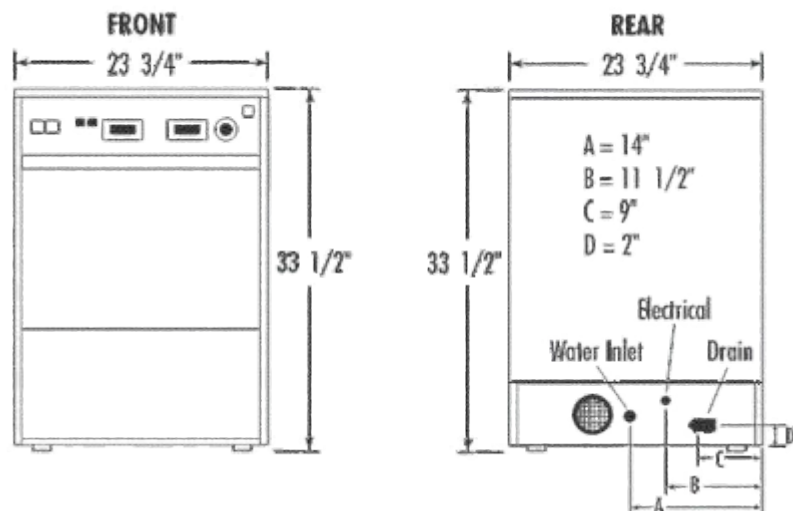
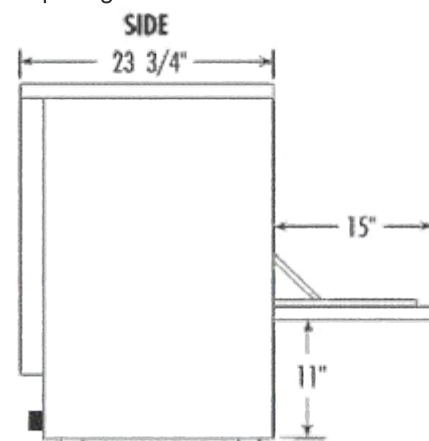

### MVP GROUP CORP.

5659 Royalmount Ave., Montreal, Qc, Canada H4P 2P9

TEL: (514) 737-9701 - TOLL FREE: (888) 275-4538

FAX: (514) 342-3854 - TOLL FREE FAX: (877) 453-8832

[www.mvpgroupcorp.com](http://www.mvpgroupcorp.com) - [sales@mvpgroupcorp.com](mailto:sales@mvpgroupcorp.com)

JET-TECH is a registered trade mark of MVP Group.  
 Specifications subject to change without notice.

WARRANTY: 1 year parts and labor. Certain conditions apply. See Owner's Manual for details.