

# ELECTRIC HOT FOOD TABLES

HFT-AW



HFT-48AW  
(OPTION 1)

**MODELS**  
**HFT-33AW**  
**HFT-48AW**  
**HFT-60AW**  
**HFT-74AW**  
**HFT-88AW**



PROJECT \_\_\_\_\_  
ITEM \_\_\_\_\_

## DESCRIPTION

- Electric steam type hot food table.
- Stainless steel top.
- 1 3/4" (44 mm) thick laminated maple wood cutting board, assembled on stainless steel brackets.
- Entirely welded 2-B finish stainless steel basin.
- 1" (25mm) drain with overflow and manual valve water inlet.
- Painted steel base with bottom shelf.
- Tubular steel legs with adjustable feet.

## OPTIONS

- Choice of containers (See drawings).
- All stainless steel finish.
- Stainless steel or painted steel sliding doors.
- Heated base.
- Stainless steel single or double overshelf with or without sneezeguard.
- Dry or humid heat controlled individual wells.
- Painted steel or stainless steel middle shelf.
- 5" diameter casters.

M.K.E. Industries (1984) Inc.

183 Montcalm Blvd. N. Candiac Qc J5R 3L6 Tel: (450) 659-6531 / 1-800-361-9801 / Fax: (450) 659-2248

[www.mke-ind.com](http://www.mke-ind.com)

10/02

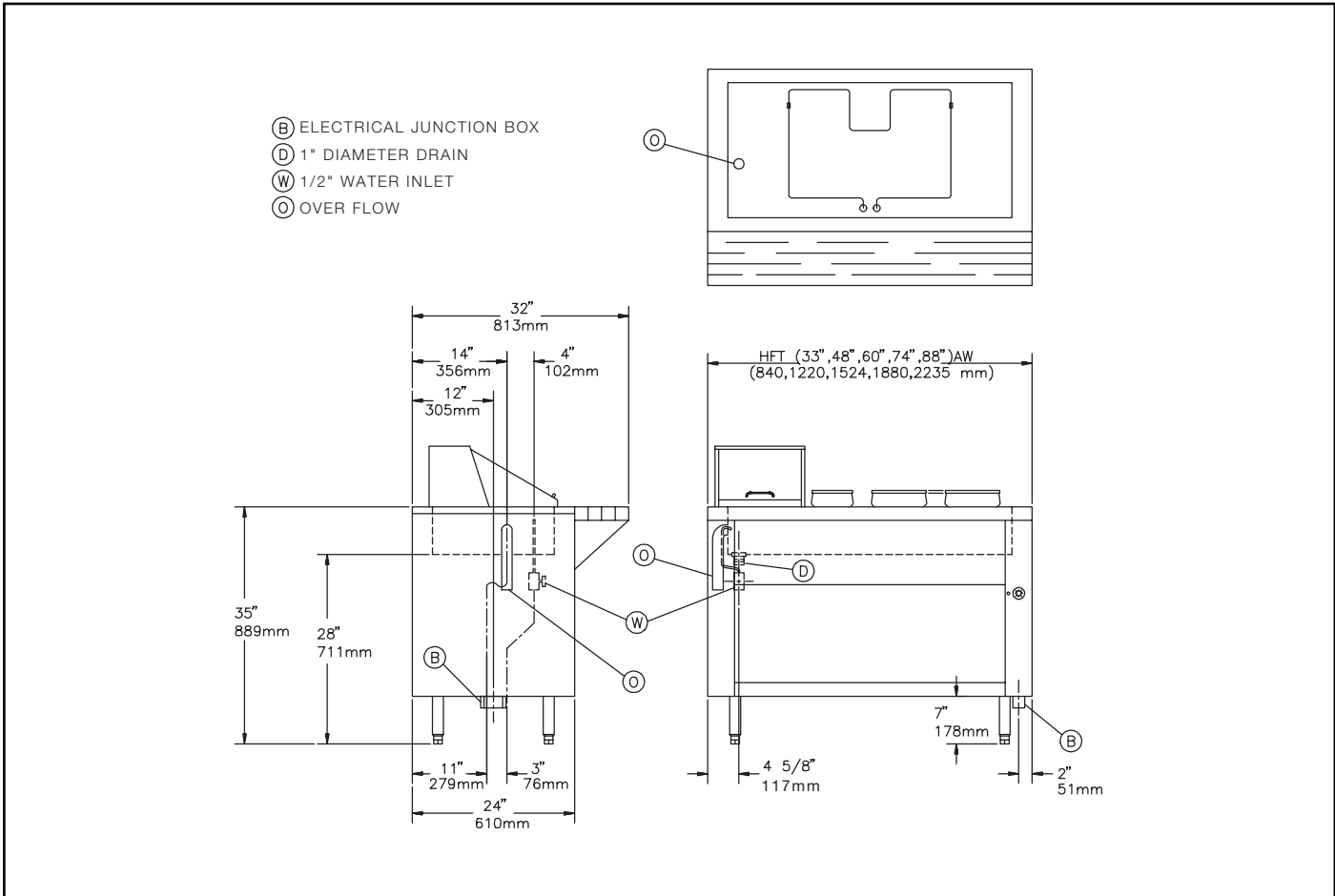

ONE BASIN WITH ONE CONTROL									
Model	Length	Depth	Height	Power (Watts)		Current (Amps)		Volume	Weight
				208V	240V	208V	240V		
HFT-33AW	33" 838 mm	32" 813 mm	35" 889 mm	2500	2500	12	10.4	29.89 ft <sup>3</sup> 0.84 m <sup>3</sup>	200 lbs. 91 kg
HFT-48AW	48" 1220 mm	32" 813 mm	35" 889 mm	3000	3000	14.5	12.5	42.35 ft <sup>3</sup> 1.19 m <sup>3</sup>	225 lbs. 102 kg
HFT-60AW	60" 1524 mm	32" 813 mm	35" 889 mm	3000	3000	14.5	12.5	52.31 ft <sup>3</sup> 1.48 m <sup>3</sup>	250 lbs. 114 kg
HFT-74AW	74" 1880 mm	32" 813 mm	35" 889 mm	5000	5000	24	21	64.25 ft <sup>3</sup> 1.81 m <sup>3</sup>	350 lbs. 159 kg
HFT-88AW	88" 2235 mm	32" 813 mm	35" 889 mm	5000	5000	24	21	75.57 ft <sup>3</sup> 2.14 m <sup>3</sup>	450 lbs. 205 kg

\* Specifications may change without notice due to continuous product improvement

M.K.E. Industries (1984) Inc.

183 Montcalm Blvd. N. Candiac Qc J5R 3L6 Tel: (450) 659-6531 / 1-800-361-9801 / Fax: (450) 659-2248

www.mke-ind.com

# ELECTRIC FOOD HOT TABLES

**HFT-AW**

OPTIONAL INDIVIDUAL WELLS AND CONTROLS										
Model	Length	Depth	Height	Number of wells	Power (Watts)		Current (Amps)		Volume	Weight
					208V	240V	208V	240V		
HFT-33AW	33" 838 mm	32" 813 mm	35" 889 mm	2	2400	3200	11.5	13.3	29.89 ft <sup>3</sup> 0.84 m <sup>3</sup>	225 lbs. 102 kg
HFT-48AW	48" 1220 mm	32" 813 mm	35" 889 mm	3	3600	4800	17.3	20	42.35 ft <sup>3</sup> 1.19 m <sup>3</sup>	250 lbs. 114 kg
HFT-60AW	60" 1524 mm	32" 813 mm	35" 889 mm	4	4800	6400	23	26.7	52.31 ft <sup>3</sup> 1.48 m <sup>3</sup>	300 lbs. 136 kg
HFT-74AW	74" 1880 mm	32" 813 mm	35" 889 mm	5	6000	8000	28.8	33.3	64.25 ft <sup>3</sup> 1.81 m <sup>3</sup>	400 lbs. 182 kg
HFT-88AW	88" 2235 mm	32" 813 mm	35" 889 mm	6	7200	9600	34.6	40	75.57 ft <sup>3</sup> 2.14 m <sup>3</sup>	500 lbs. 227 kg

A: 6" (152mm)  
 B: 8" (203mm)  
 C: 10" (254mm)  
 F.S. : 12" x 20" (305mm x 508mm)

NOTE: When ordered with pans and covers, 1 telescopic lid is supplied with options 1 and 3. Two telescopic lids are supplied with option 2.

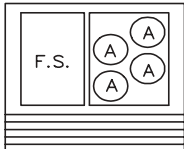

HFT-33  
OPTION 1

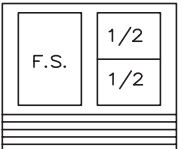

HFT-33  
OPTION 3

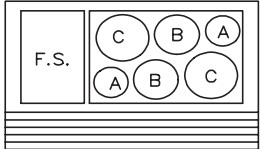

HFT-48  
OPTION 1

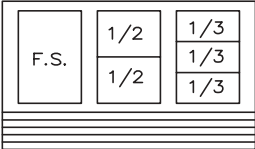

HFT-48  
OPTION 3

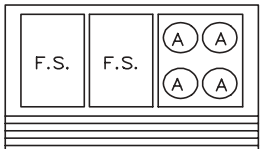

HFT-48  
OPTION 2

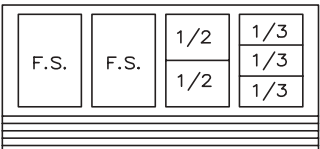

HFT-60  
OPTION 3

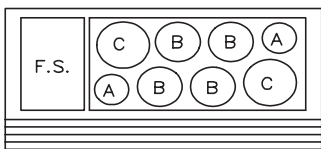

HFT-60  
OPTION 1

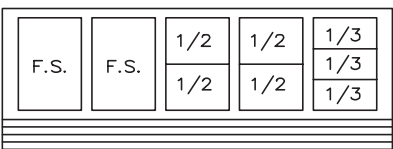

HFT-74  
OPTION 3

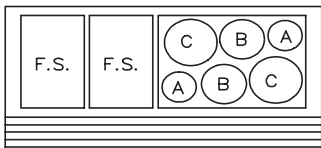

HFT-60  
OPTION 2

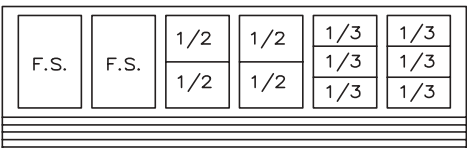

HFT-88  
OPTION 3

\* Specifications may change without notice due to continuous product improvement