

HOBART701 S Ridge Avenue, Troy, OH 45374
1-888-4HOBART • www.hobartcorp.com**FD3/150 FD3/200 FD3/300
FOODWASTE DISPOSERS****HOBART****FD3/150 FD3/200 FD3/300 FOODWASTE DISPOSERS****MEDIUM SIZE
FAST, ECONOMICAL**

In a profitable foodservice operation, there's no space, time or budget allowance for inefficient food waste handling. Here are the medium sized disposers that can end food waste storage, removal and clean-up – fast, economically.

SPECIFICATIONS

Listed by Underwriters Laboratories Inc. and meets requirements of A.S.S.E. Standard No. 1009 (50 Hz. Electrical Specifications not UL Listed).

MOTORS: Continuous duty rating, equipped with manual reset thermal overload inherent protection. Permanently lubricated ball bearings for upper and lower shaft support.

HOUSINGS: Heavy aluminum grind and discharge housings. Four bolts fasten the motor unit to the grind chamber, permit easy removal.

LEGS: Tubular stainless steel with bullet feet to support housing. Adjustable to 3 inches in either direction.

MOUNTING: All Hobart Disposers fasten to 7" I.D. (throat opening) cones. A vinyl isolating ring eliminates metal-to-metal contact at the cone mounting, reduces vibration and noise transmission.

STATIONARY SHREDDER RING: Abrasion resistant, Ni-Hard, 2¼" high, 4 machine ground primary action breaker bars, 42 secondary action grinding teeth.

FLYWHEEL: Offset breaker blade, mounted at center, speeds grinding, prevents objects from "riding" at center. Two hardened stainless steel cutter blocks (fastened to flywheel with nylon locking screws) are replaceable, can be indexed for new cutting edges. Corrosion resistant Ni-Resist flywheel is 7³/₁₆" diameter, slots undercut the shredder ring to assure that particles are cut to proper size before passing to the drain line.

MOTOR SHAFT SEAL: Face-type seal consists of sintered bronze mating ring and spring loaded carbon ring insert in chemical resistant neoprene bellows. Mating surfaces are protected from grit or fibers by being recessed into flywheel. Should any moisture pass this seal, a flinger and drain tube are provided to insure immediate removal. In addition, a lip-type oil seal (located beneath the bearings) is an "added protection" water seal.

DRAIN CONNECTOR: The removable outlet flange is tapped for 2" pipe connection.

DUAL DIRECTIONAL GRINDING: Hobart Disposers operate in either direction of flywheel rotation. Direction of rotation can be controlled by the operator (to increase life and efficiency of grinding elements – back flywheel free of a "jam") when installed with Control Groups 5 & 6.

WEIGHT: Shipping – Approx. 95 lbs. (does not include accessory group or controls).



FD3/150 FD3/200 FD3/300 FOODWASTE DISPOSERS



701 S Ridge Avenue, Troy, OH 45374
1-888-4HOBART • www.hobartcorp.com

ACCESSORY GROUPS

GROUP A



Nitrile Rubber Scrapping Ring



Stainless Steel Silver-Saver Sleeve with Side Feed Hole



Water Swirl



Vacuum Breaker

GROUP B



Nitrile Rubber Silver-Saver Splash Guard Ring



Water Swirl



Vacuum Breaker

GROUP C



Nitrile Rubber Silver-Saver Splash Guard Ring



Vacuum Breaker



Pre-Rinse Spray with Wall Bracket

GROUP D



Nitrile Rubber Silver-Saver Splash Guard Ring



7" I.D. Stainless Steel Weld-in Adapter for Sink



Fixed Direction Water Inlet for Sink



Vacuum Breaker

ACCESSORY COMPONENTS

CONES-SINK – Stainless Steel



Part No.

Cone 15" I.D. w/hole for water swirl inlet 204007

Cone 18" I.D. w/hole for water swirl inlet 204004

Cone 15" I.D. w/out swirl hole 204006

Cone 18" I.D. w/out swirl hole 204003



Sink 16" x 20" x 7" (7" opening) w/hole for water inlet.....204015-2

WATER INLETS



Cone Water Swirl Inlet 1/2" N.P.T..... 204380



Fixed Direction Water Inlet (for sinks or troughs) 1/2" N.P.T. 204346

FLOW CONTROL



8 Gallons per minute for Models FD/150 through FD/300 - 3/4" N.P.T. 204368

CONE COVER – STAINLESS STEEL



15" Cone cover w/feed hole 204024

18" Cone Cover w/feed hole..... 204023

CONE FEEDING ACCESSORIES



Part No.

Nitrile Rubber Scrapping Ring 202113



Stainless Steel Silver-Saver Sleeve with side feed hole..... 203870

SILVER-SAVER SPLASH GUARD RING



Nitrile Rubber Silver-Saver and Splash Guard Ring (for 7" opening cones, sinks and adapter)..... 202120

SINK ADAPTER – Standard Group D Accessory



7" I.D. Stainless Steel Adapter for Welding to Sink or Trough 204853

VACUUM BREAKERS – Luster Chrome Plated



3/4" 74338

PRE-RINSE SPRAYS

PR-3 Heavy-duty Flexible Pre-rinse Spray (38" high with wall bracket) ML-32333



Adapters are available to install Hobart Disposers on existing cones. See Form F7543.



701 S Ridge Avenue, Troy, OH 45374
1-888-4HOBART • www.hobartcorp.com

FD3/150 FD3/200 FD3/300 FOODWASTE DISPOSERS

ELECTRICAL CONTROL GROUPS Listed by Underwriters Laboratories Inc., for use with FD3 Disposers (50 Hz. Electrical Specifications not UL listed)

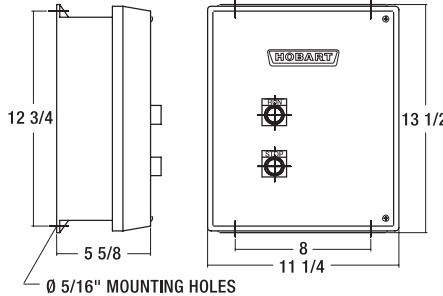

Group 5 - For all Models
Includes:
Magnetic Contactors
Pushbutton Start and Stop
Automatic Reversing
NEMA 4 Enclosure
Solenoid Valve (24 V only)

Approximate
Shipping Wt. 19 lbs.

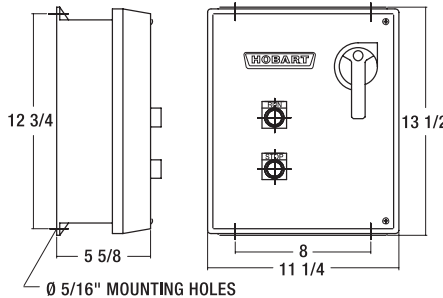

Group 6 - For all Models
Includes:
Magnetic Contactors
Pushbutton Start and Stop
Automatic Reversing
Time Delay for water after shut-off
Line Disconnect
Solenoid Valve (24 V only)
NEMA 4 Enclosure

Approximate
Shipping Wt. 20 lbs.

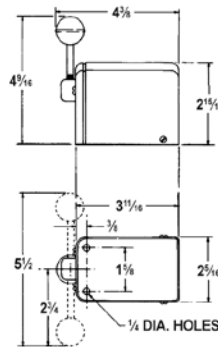

Group 4 - For Model FD3/150 and FD3/200
Includes:
Manual Reversing Switch
NEMA 1 Enclosure or NEMA 4 Enclosure
Not available above 250 volts
Optional Solenoid Valve

Approximate
Shipping Wt. 11 lbs.

Model	H.P.	Ph.	Hz.	Volts	Rated Amps
FD3/150	1 1/2	1	60	120/208-240	17.2/8.2-8.6
	1 1/2	3	60	208-240/480	4.8-4.8/2.4
FD3/200	2	1	60	120/208-240	20.0/10.0
	2	3	60	208-240/480	6.8-6.5/3.3
FD3/300	3	3	60	208-240/480	9.0-8.0/4.0
FD3/150	1 1/2	1	50	110-120/220-240	See customer service
	1 1/2	3	50	220-240/380-415	5.7-6.1/2.7-2.7
FD3/200	2	1	50	110-120/220-240	See customer service
	2	3	50	220-240/380-415	6.7-7.0/3.4-3.4
FD3/300	3	3	50	220-240/380-415	9.0-8.7/4.8-4.6

The slant (/) indicates the dual voltage operation accomplished by motor lead connection; follow connecting diagram on motor.

SAMPLE SPECIFICATION

FD3-200 — B — 4 (240/60/3)

Electrical Specifications

Electrical Control Group

Accessory Group

Model Number

Cut hole 19" for 18" cone. Hole to be 16" for 15" cone.

Solenoid must be installed in upright position.

Disposer may be easily rotated for better drain line connection.

Center line at wall outlet of trap should not be higher than center line of disposer discharge opening

If water pressure is in excess of 60 P.S.I. install a pressure reducing valve.

FD3/150 FD3/200 FD3/300 FOODWASTE DISPOSERS



701 S Ridge Avenue, Troy, OH 45374
1-888-4HOBART • www.hobartcorp.com

DETAILS AND DIMENSIONS

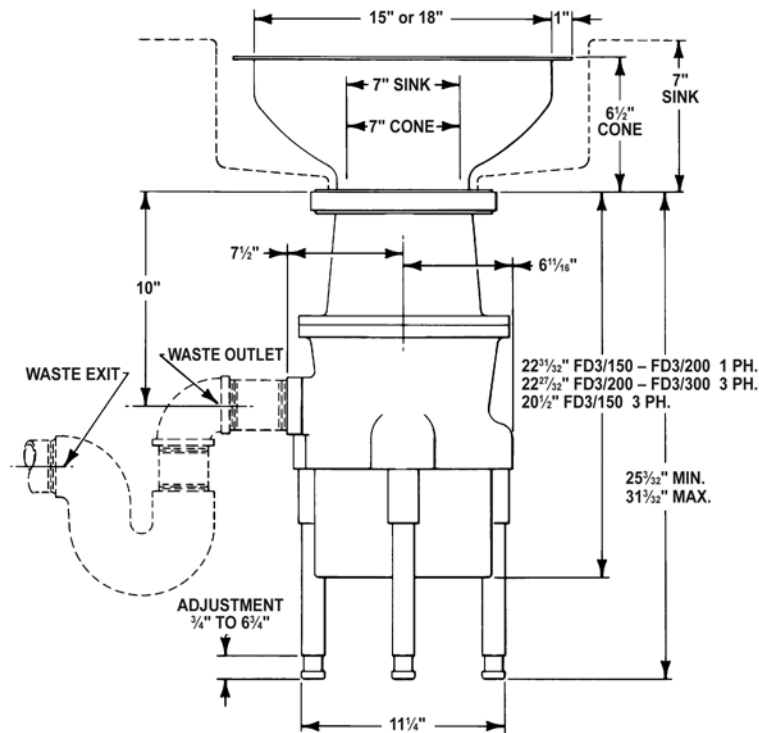

NOTE: Specify 15" or 18" Cone When Desired.

TYPICAL INSTALLATION

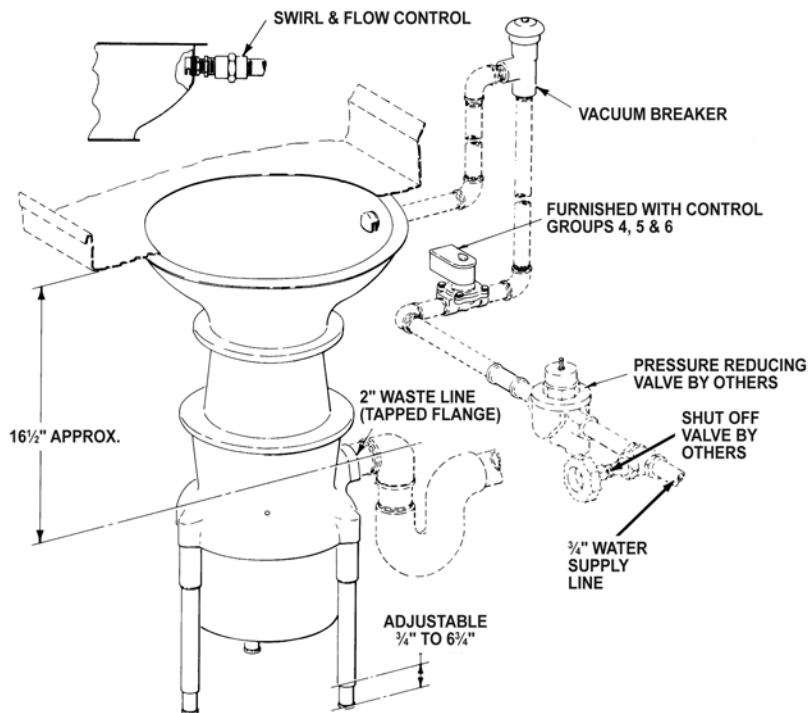

As continued product improvement is a policy of Hobart, specifications are subject to change without notice.