



PRO-MAX® GROOVED TWO-SIDED GRILLS

Models CG10I, CG14, CG14I, CG14IGT, CG28I & CG28IGT

Features/Benefits

- ★ Expand your menu with Star's Pro-Max two sided grill. Prepare "Panini" sandwiches, chicken breasts, hamburgers, steaks, wraps vegetables and many other menu items quickly and easily while maximizing space.
- ★ Available in 10", 14" and 28" width platens to fit a variety of foodservice operations.
- ★ Heavy-duty cast iron or aluminum platens provide long life and superior performance for high volume operations.
- ★ A heavy-duty commercial counter balance hinge system and handle provides safe and effortless operation of the top platen.
- ★ Spacious grilling height accommodates product up to 3" with 3-4 pounds of pressure for proper cooking between platens.
- ★ Two-sided cooking heats your menu items in half the time, sealing in the flavor.
- ★ The bottom platen has a patented splash guard to help keep products and grease in their place.
- ★ Ergonomically designed control panel provides easy access and visibility to controls and grease drawer.
- ★ Heavy gauge, water resistant flexible plastic conduit protects electrical connections.
- ★ Thermostat is rated from 175°F (79°C) to 550°F (302°C) and provides accurate sensing of temperature.
- ★ Removable, large capacity grease drawer in the front of unit for easy clean up.



Model CG10I



Model CG14

Application:

Star's Two-Sided Grills can prepare sandwiches, chicken breasts, wraps, hamburgers and a variety of other menu items in your restaurant, cafe, concession stand, bar, or wherever you need high performance cooking. Grills are compact and portable providing flexibility in your operation.

Quality Construction:

Star's Two-Sided Grills are constructed of 18 gauge stainless steel. Units available with cast iron or aluminum grooved platens. Star's counter balance hinge mechanism is constructed of hardened aluminum for strength and durability. Metal tubular elements are standard. The lead-in cord is resistant to water and oil and has metallic braiding to protect wiring. Furnished with a 6' cord and standard NEMA plug.

Warranty:

Star's Two-Sided Grills are covered by Star's one year parts and labor warranty.

Patent No. 6,257,126





PRO-MAX® GROOVED TWO-SIDED GRILLS

Models CG10I, CG14, CG14I, CG14IGT, CG28I & CG28IGT

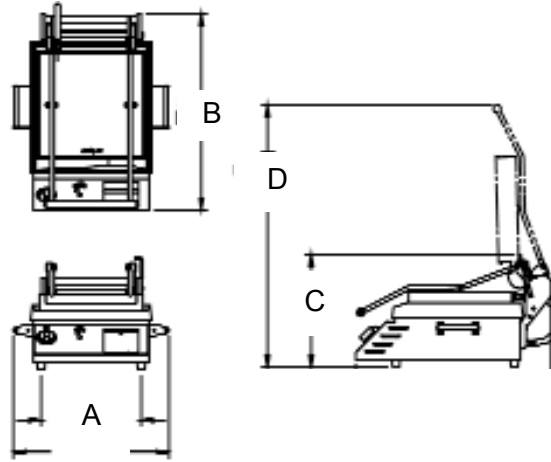

Model and Specifications

Model No.	Grid Surface	(A) Width (cm)	(B) Depth (cm)	Height		Voltage	Wattage	Amps	NEMA	Approximate Weight	
				(C) Closed (cm)	(D) Open (cm)					Shipping (kg)	Installed (kg)
CG10I	Iron	16-1/8"	21-1/8"	14-1/4"	28-3/4"	120	1800	15	5-15P	67 lbs.	57 lbs.
		(40.9)	(53.7)	(36.2)	(73)	120	1800	15	5-20P*		
						208/240	1350/1800	6.5/7.5	6-15P	(30.4)	(28.1)
CG14	Alum.	19-5/8"	24-5/8"	14-1/4"	33"	120	1800	15	5-15P	67 lbs.	55 lbs.
		(49.8)	(62.5)	(36.2)	(83.8)	120	1800	15	5-20P*		
						208/240	1350/1800	6.5/7.5	6-15P	(29.5)	(24.9)
CG14I	Iron	19-5/8"	24-5/8"	17-1/4"	36"	208/240	2700/2600	13/15	6-15P	67lbs.	55 lbs.
		(49.8)	(62.5)	(43.8)	(91.4)					(29.5)	(24.9)
CG14IGT	Iron	19-5/8"	24-5/8"	17-1/4"	36-1/2"	208/240	2700/3600	13/15	6-15P	67 lbs.	55 lbs.
Grooved Top Only		(49.8)	(62.5)	(43.8)	(92.7)					(29.5)	(24.9)
CG28I	Iron	31-1/4"	24-5/8"	17-1/4"	36"	208/240	5400/7200	26/30	L6-30P	206 lbs.	171 lbs.
		(87)	(62.5)	(43.8)	(91.4)	208/240	5400/7200	26/30	6-50P*	(93.4)	(77.5)
CG28IGT	Iron	31-1/4"	24-5/8"	17-1/4"	36"	208/240	5400/7200	26/30	L6-30P	206 lbs.	171 lbs.
		(87)	(62.5)	(43.8)	(91.4)	208/240	5400/7200	26/30	6-50P*	(93.4)	(77.5)

*Canadian Requirement

Note: Units weighing more than 80 pounds have standard 4" legs.

Typical Specifications

Two-Sided Grills are constructed with an 18 gauge stainless steel body. Cast iron or aluminum grooved platens are standard. A counter balance mechanism provides easy operation for the top platen. Grilling height between platens is up to 3" with counter balance system providing 3-4 pounds of pressure to the cooking product placed on bottom platen. Metal sheathed tubular elements shall be provided as standard. Adjustable non-skid feet shall be standard. Unit shall be provided with pilot light, six foot power cord with Nema rated plug (see specifications above). Units carry approval of UL, UL Sanitation or UL Canada Standards. Printed in the U.S.A.

Due to periodic changes in designs, methods, procedures, policies and regulations, the specifications contained in this sheet are subject to change without notice. While Star Manufacturing exercises good faith efforts to provide information that is accurate, we are not responsible for errors or omissions in information provided or conclusions reached as a result of using the specifications. By using the information provided, the user assumes all risks in connection with such use.

Star Manufacturing International Inc. - 10 Sunnen Drive - P.O. Box 430129 - St. Louis, MO 63143-3800

Phone: (800) 264-7827 - FAX: (800) 264-6666 - www.star-mfg.com