



COMMERCIAL RESIN FURNITURE

Your best value for Food Service & Hospitality!

# New Color!

## Havana Classic Stacking Barstool

Seat and footrest tested to 400 lbs. static load and 150 lb. impact test.

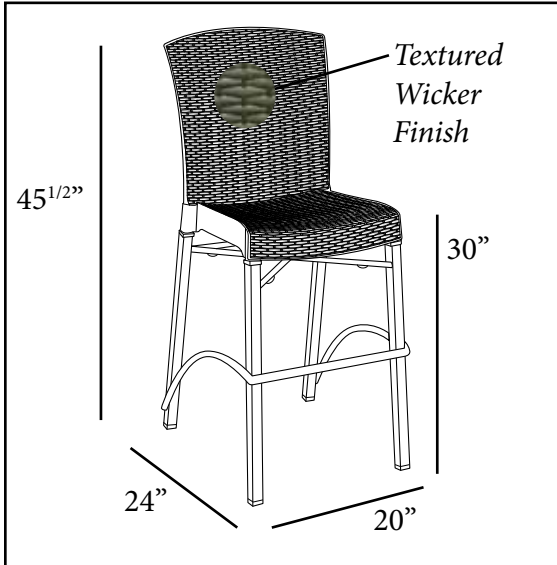

**Features & Benefits** **Warranty: 3 Yrs.**

- The All-Weather Wicker performance, without the maintenance!
- A product of Grosfillex MPC Technology®
- Stacks for easy storage.
- Rated to 300 lbs. for safe use in commercial areas.
- Texture will not harbor dirt, sand, food, bacteria nor fungi.
- Easy to clean with soap and mild detergent and water.
- 1 1/4" square powder coated aluminum base with hard wearing footpads for structural integrity.
- Color-fast - no resin strand to unravel.

<b>Product Specifications</b>						
Product Description	Reference Number	Color	UPC Code 014306	Weight Each (lbs.)	Master Pack	Master Pack Volume (cu. ft.)
Havana Classic Stacking Barstool	49626037	Espresso	141671	17.60	8	68.26
	US626037	Espresso	141671	17.94	2	20.34
	49626008	Tobacco	141664	17.60	8	68.26
	US626008	Tobacco	141664	17.94	2	20.34
<i>New Color!</i>	49626004	White	142340	17.60	8	68.26
	US626004	White	142340	17.94	2	20.34
	49626002	Charcoal	909967	17.60	8	68.26
	US626002	Charcoal	909967	17.94	2	20.34