

Pourover Coffee Brewer with 3 Warmers

Features

Low Profile Pourover Coffee Brewer

- Brews 3.8 gallons (14.4 liters) of perfect coffee per hour.
- Pourover brewer requires no plumbing – completely portable.
- All stainless steel construction.
- Stainless steel or black decor.
- Three separately controlled warmers.
- SplashGard® funnel deflects hot liquids away from the hand.
- International electrical configurations available.



Model VP17-3T SS*

Shown with decanters.
(decanters sold separately)

Dimensions: 18.9" H x 8.5" W x 17.7" D
(48cm H x 21.6cm W x 45cm D)



Model VP17-3 BLK

Shown with decanters.
(decanters sold separately)

Dimensions: 17.8" H x 16.4" W x 17.7" D
(45.2cm H x 41.7cm W x 45cm D)

For current specification sheets and other information, go to www.bunn.com.

* International models may vary in appearance.

Related Products

Paper Filter Pack

Product No. : 20115.6000

Packed per case: 1,000

Dimensions: 4 1/4" Base x 2 3/4" Sidewall
10.8 cm Base x 6.98 cm Sidewall



WX1-warmer

Product No. : 06450.6000

One position warmer



Easy Pour® black decanter

Product No. : 06100.0201

Quantity: 1 (also packaged in quantities of 3, & 24)



B1-warmer

Product No. : 18000.6001

One position warmer

Black Finish



WX2-warmer

Product No. : 06310.6000

Two position warmer



Easy Pour® orange decanter (for decaf)

Product No. : 06101.0101

Quantity: 1 (also packaged in quantities of 3, & 24)





B2-warmer

Product No. : 18000.6002

Two position warmer

Black Finish



Model	Agency Listing	International Model	Agency Listing
VP17-3 SST		VP17A-3	 SASO
VP17-3 BLK			

Dimensions & Specifications



Model	Product #	Volts	Amps	Heater Watts	Total Watts	Capacity per hour	Cubic ft ³ /m ³	Weight lbs. / kg.	Cord Attached
VP17-3 BLK (3 lwr)	13300.6004	120	12.5	1150	1500	3.8 gal/14.4 liter	6.9/0.2	36 lbs.(16.3 kg)	Yes*
VP17-3 SS (3 lwr)	13300.6005	120	12.5	1150	1500	3.8 gal/14.4 liter	6.9/0.2	36 lbs.(16.3 kg)	Yes*
VP17-3T BLK (2 up)	13300.6028	120	12.5	1150	1500	3.8 gal/14.4 liter	3.1/0.1	25 lbs.(11.4 kg)	Yes*
VP17-3T SS (2 up) [†]	13300.6011	120	12.5	1150	1500	3.8 gal/14.4 liter	3.1/0.1	25 lbs.(11.4 kg)	Yes*

*Power cord (NEMA 5-15P) 15 amp 120 V machine only. [†]Includes Stainless Steel Funnel
Brewing capacity: based upon incoming water temp of 60°F (140°F rise) per 1/2 gallon brew time of 4 minutes.

Electrical: Models require 2-wires plus ground service rated 120V, single phase, 60 Hz.

Plumbing: No plumbing required.

2 Upper Warmers

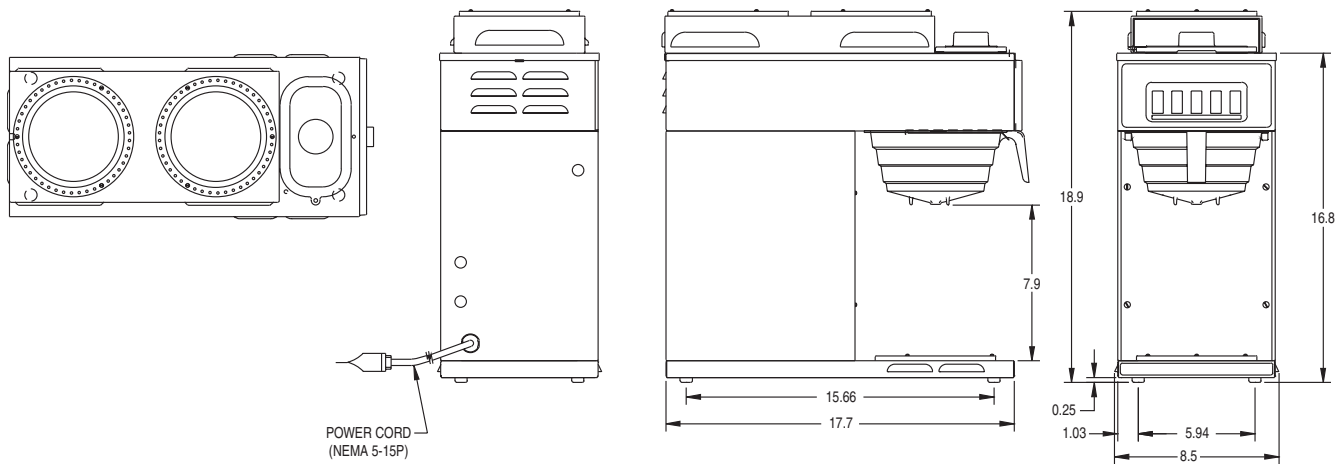

3 Lower Warmers

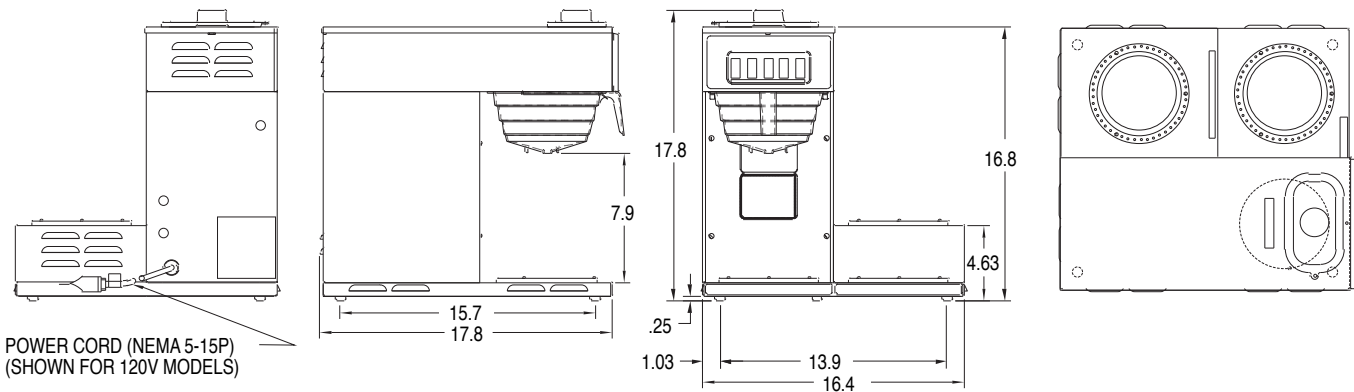

BUNN Corporation - 1400 Stevenson Drive Springfield, Illinois 62703 • 800-637-8606 • 217-529-6601 • Fax 217-529-6644 • www.bunn.com

BUNN® practices continuous product research and improvement. We reserve the right to change specifications and product design without notice. Such revisions do not entitle the buyer to corresponding changes, improvements, additions or replacements for previously purchased equipment.

All dimensions shown in inches. Bunn Corporation owns all copyrights relating to materials in this publication. Please contact Bunn Corporation to request permission to reproduce any portion of this publication.