



Cuisine Series Heavy Duty Broiler W/Non-Adjustable Racks

Item: _____
 Quantity: _____
 Project: _____
 Approval: _____
 Date: _____

Cuisine Series Heavy Duty Broiler W/Non-Adjustable Racks

Models:

- C0836-18A C0836-24A C0836-36A C0836-48A
 C0836-18AM C0836-24AM C0836-36AM C0836-48AM C836-36A

Char-Broiler With Non-Adjustable Racks

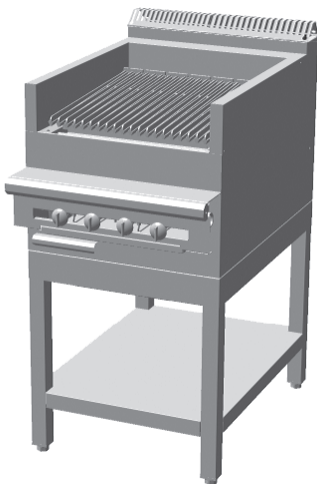

Model C0836-24AM

NOTE: Ranges supplied with casters must be installed with an approved restraining device.

Standard Features:

- Stainless steel front and sides and back stub
- Individual burner controls every 6" (152mm)
- Automatic lighting
- 1-1/4" NPT gas manifold
- Chrome steel adjustable legs
- Can be connected individually or in a battery
- Cast iron radiants
- Reversible grates - one side with grease trough
- Three bar grate design
- Dual grease containers
- Stainless steel oven interior w/ removable porcelain bottom
- 40,000 BTU oven burner
- Chrome plated rack with four positions, 1 per oven
- Fully insulated oven interior
- 100% safety oven pilot
- Oven thermostat control - 150°-500°F (66°-260°C)

Optional Features:

- Stainless steel back

- Range base convection oven (add RC)
- Porcelain oven interior in lieu of stainless steel interior - NC
- Single or double deck high shelf or back riser
- Modular unit w/ legs & shelf (suffix M)
- Modular unit w/o legs on Refrig. Base (change suffix M to PC)
- Stainless steel door(s) for cabinet base units
- Gas shut-off valves - 3/4", 1", 1 1/4" NPT (Specify)
- Gas regulator: 3/4"- 1 1/4" NPT (Specify)
- Gas flex hose w/ quick disconnect 3/4", 1", 1 1/4" (Specify)
- Stainless steel legs (set of four)
- Flanged feet set of four
- Swivel casters (4) w/ front locking
- Casters w/ polyurethane wheels - non marking
- Extra oven rack
- 3/4" max. 250,000 BTU , Rear gas connection (right-hand side only) w/front manifold capped and covered:

Specifications:

U.S. Range Cuisine Series Range Match Char-Broiler, Model _____ with total BTU/HR rating of _____ when used with natural/propane gas. Stainless steel front and sides and 6" (152mm) legs with adjustable feet.

Note: Range-based convection oven models can be located in the middle of a battery, banked back-to-back with other equipment, and can be positioned against a wall



Garland Commercial Industries, LLC
 185 East South Street
 Freeland, PA 18224
 Phone: (570) 636-1000
 Fax: (570) 636-3903

Garland Commercial Ranges Ltd
 1177 Kamato Road,
 Mississauga, Ontario
 L4W 1X4 CANADA
 Phone: 905-624-0260
 Fax: 905-624-5669

Enodis UK LTD
 Swallowfield Way,
 Hayes, Middlesex
 UB3 1DQ ENGLAND
 Telephone: 081-561-0433
 Fax: 081-848-0041



Model #	Description	Total BTU (NAT. Gas)
C0836-18A	CI Radiants w/Non-Adj. Grate - 18" Wide w/SB	54,000
C0836-18AM	CI Radiants w/Non-Adj. Grate - 18" Wide MT	54,000
C0836-24A	CI Radiants w/Non-Adj. Grate - 24" Wide w/SB	72,000
C0836-24AM	CI Radiants w/Non-Adj. Grate - 24" Wide MT	72,000
C836-36A*	CI Radiants w/Non-Adj. Grate - 36" Wide w/Oven	148,000
C0836-36A	CI Radiants w/Non-Adj. Grate - 36" Wide w/SB	108,000
C0836-36AM	CI Radiants w/Non-Adj. Grate - 36" Wide MT	108,000
C0836-48A	CI Radiants w/Non-Adj. Grate - 48" Wide w/SB	144,000
C0836-48AM	CI Radiants w/Non-Adj. Grate - 48" Wide MT	144,000

Clearances Non-Combustible Wall Instillation Only,	
Sides	Back
0" (0mm)	0" (0mm)

Gas Pressure	NAT.	PRO.
Min. Supply	7" WC	11" WC
Manifold Operating	6" WC	10" WC
Gas Manifold 1-1/4" NPT		

Individual Burner Ratings (BTU/hr)		
Burner/Section	NAT.	PRO.
Cast Iron Radiant	18,000	
Standard Oven	40,000	35,000
Convection Oven	37,000	35,000

CI = Cast Iron, SB = Storage Base, MT = Modular Top on Stand

* Add Suffix "RC" for Convection Oven Base (i.e. C836-36ARC)

Interior Dimensions: In (mm)			
Product	Height	Width	Depth
Standard Oven	13-1/2(323)	26-1/4 (667)	29 (737)
Convection Oven	13-1/2(323)	26-1/4 (667)	25 (635)
Cabinet Base	20-1/2 (521)	32-1/4 (819)	31 (787)

Char Broiler Exterior Dimensions In (mm)				
Series	Width	Depth	Height w/o Legs	Height with Legs
C0836-18A	18 (457)	37-7/8 (962)	30 (762)	36 (914)
C0836-24A	24 (610)	37-7/8 (962)	30 (762)	36 (914)
C0836-36A	36 (914)	37-7/8 (962)	30 (762)	36 (914)
C0836-48A	48 (1219)	37-7/8 (962)	30 (762)	36 (914)

Many local codes exist and it is the responsibility of the owner and installer to comply with those codes.

These appliances are intended for commercial use by professionally trained personnel.

Model C0836-48AM shown

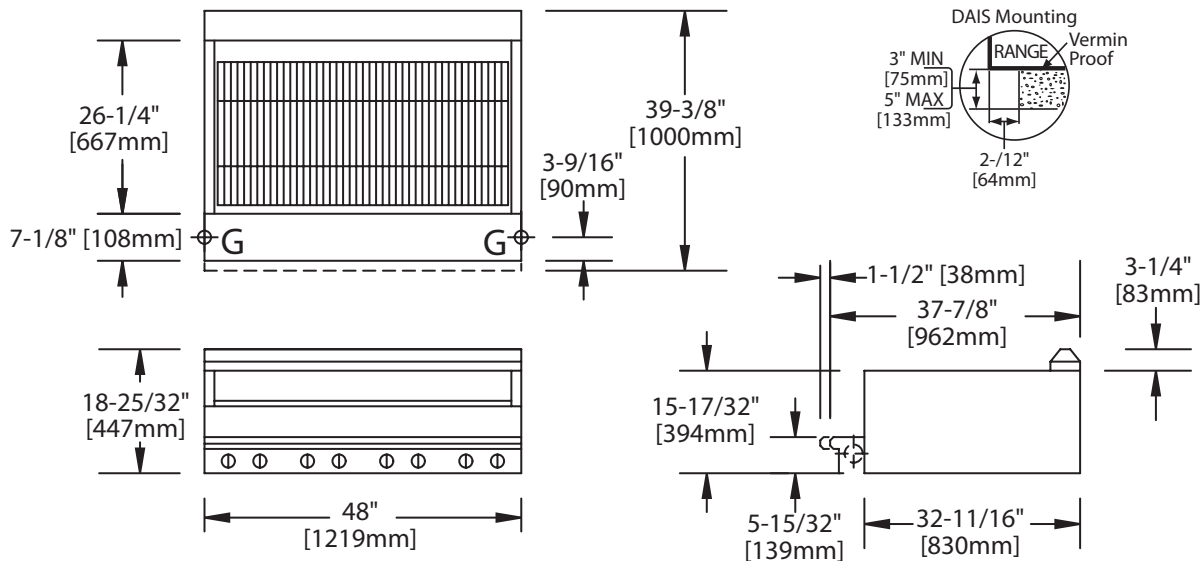

Form# C0836-18/24/36/48A/M (08/07)